

PNEUMATIC TOOL P145

The pneumatic flooring tool P145 is a tool specially developed for the installation standard 3/4" to 1/2" hardwood flooring. It has been designed for easy maintenance where major components can be easily accessed. It makes the installation of hardwood floor very easy, allowing the operator to set and fasten the boards in the standing position.

The **P145** nailer/stapler takes both standard L-type 16GA flooring nails and 1/2" crown 15 1/2GA flooring staples.

Complete documentation specific to your tool can be retrieved by scanning the QR-Code applied on the tool. You will find updated information such as Operation Manual, Part list, Schematic specifics and Technical Notes specific to your tool as it was manufactured; as well as useful information for ordering replacement parts.

Technical support, information & schematics at <http://ts.primatech.ca/145>



SAFETY MEASURES

These important guidelines should always be followed to work safely with the Primatech pneumatic tool P145:

- Read these instructions thoroughly before using this tool and keep it handy for reference if necessary.
- Always keep hands, feet or other body parts away from the fastener ejection area.
- Never aim the tool in any direction other than the working area.
- Always carry or manipulate the tool by its handle while the air supply hose is connected.
- Never hit the head cap of the actuator if the base is not sitting perfectly on the working surface.
- Never leave the tool laying down on its side while the air supply hose is connected; the tool should always be left on the floor, standing on its base.
- Always disconnect the air supply hose when the tool is not in use or when move to another work area.
- Never service or repair the tool, clear obstructions or make adjustments while the air supply hose is connected.
- Only compressed air should be used to power this tool; do not exceed 110 psi (7.6 bar).
- Never use oxygen or any other compressed gas as a power source for this tool. Explosion may occur.
- Always wear OSHA-required Z-87 safety glasses with side shields.

- Always wear proper ear and foot protection while the air supply hose is connected.
- Always remove fasteners from the magazine before servicing tool.

Eye protection is recommended and should be worn by the operator and other in working area. Accidental ejection of fasteners or wood debris could cause severe eye injury.

In some environments, ear protection might be required, as working condition may include exposure to high noise levels which lead to hearing damage.

Wearing safety boots and safety hat is also highly recommended.

Note: All the personal protection equipments must meet national standards.



CONNECTION & AIR SUPPLY

This tool requires clean & dry air. The use of a filter and a pressure regulator is recommended.

Use a detachable male coupler with 3/8" NPT male threads. The use of a 3/8" (1 cm) diameter air supply hose is recommended. A smaller hose or a hose longer than 50' (15 m) could cause a pressure drop when the tool is activated repeatedly.

⚠ Always use a free-flow connection for the compressed air supply to prevent that the tool stays charged after disconnecting the air supply hose.

⚠ Unload tool before connecting air to prevent accidental discharge.

⚠ To prevent injury or accidental damage to the finished surface of the installed floor, rest the tool onto the subflooring when connecting air, moving tool to a different work area, loading the tool or performing any maintenance to the tool.

Dirt, dust, and other particles in the air supply can cause sluggish operation or premature wear. Drain water from the compressor tank regularly. The compressor start-stop limits should be set to deliver an air pressure of at least 100 psi (7 bar) at all times. Consult the compressor manual or dealer for instructions on how to make this adjustment.

This tool is designed to be operated with a compressed air pressure of 80 to 100 psi (5.5-7.0 bar). Air pressure of 90 psi (6.2 bar) is adequate for most situations, although occasionally, a higher pressure could be necessary. Never not use a compressed air pressure higher than 110 psi (7.6 bar).

PREVENTIVE MAINTENANCE

This tool requires minimal lubrication. Use only detergent-free oil such as Primatech P-090. Few drops of oil weekly in the air inlet is sufficient. Other types of lubricant may degrade the seals.



Check periodically to make sure that the head assembly is fully screwed onto the main body. A loosen head will damage the tool.

LOADING THE TOOL

This tool can be used with either standard 16ga flooring cleats or with 15½ga flooring staples:

- L-type 16GA nails in lengths of 1½" (38 mm), 1¾" (45 mm) or 2" (50 mm)
- ½" crown 15½GA staples in lengths of 1½" (38 mm), 1¾" (45 mm) or 2" (50 mm)

⚠ Use only the type of fasteners identified on the magazine. The use of any other type of fasteners will damage the tool.

Loading the tool with flooring staples:

- Press the lock and open the magazine cover.
- Insert one or two strips of flooring staples over the central guide of the magazine as illustrated below (left).
- Push the magazine cover forward into its locked position.

Loading the tool with L-type 16GA flooring nails:

- Press the lock and open the magazine cover.
- Place a strip of flooring cleats against the inner side of the magazine, the "L" head of the cleats engaging the groove as illustrated below (right). Small magnets will hold it in place.
- Push the magazine cover forward into its locked position.



Unloading cleats or staples

- To remove fastener from the magazine, press the lock and open the magazine cover
- Tilt the tool to slide back remaining fastener and take them out.

⚠ Always operate the tool with fasteners in magazine. Damage may occur if the tool is operated without fasteners.

OPERATION

Unload tool and rest it onto the subflooring, Connect the hose and cycle tool once or twice without fasteners. After loading the tool, the P145 nailer/stapler is ready for use.

Use only the hammer supplied with the tool. The use of other type of hammers may affect performance. The rubber face of the hammer can be used with care to help position the boards.

With the flooring firmly in place, position the tool onto the flooring and apply downward pressure to ensure proper seating of the fastener. Strike the head cap with the hammer to activate the tool, **Use only the RUBBER FACE of the hammer to activate the tool. Using the steel end will damage the tool and void the warranty.** If wood is slightly twisted, hitting the tool with more force will assist in pulling the board up snugly. **NEVER** strike the head cap when the tool is not sitting on the working surface.



Before starting an installation, fasten down few boards to ascertain that the tool is properly adjusted. Always comply with all manufacturers recommendations.

MAINTENANCE & REPAIR

Most maintenance to the tool can be made with the 5 mm Allen wrench supplied with the tool.

Disassembly of the tool must be done in a clean environment. Some parts can be easily damaged if disassembled with improper tools or by inadequate methods. Maintenance should only be performed by trained personnel. Use only genuine Primatch replacement parts.



To prevent injury, ALWAYS disconnect the air supply hose when servicing or disassembling the tool.

When servicing the tool, do not twist or force any parts. Damage may result from such abuse. Contact your Primatch distributor for more information.

When opening the tool for maintenance, always clean all components of dirt, grit, or particles. Inspect the tool carefully for broken parts or excessive wear, and replace if necessary. When ordering parts, be sure to specify the right part number, as well as the tool serial number.



After any maintenance to the tool, REMOVE ALL Fasteners before connecting air and actuate the tool repeatedly over a piece of wood or subflooring to insure proper operation.

DISASSEMBLING THE TOOL

All pneumatic components can be easily accessed with the use of an Allen key. This section describes how to disassemble the tool to access its internal components.

To access valve and piston assemblies:

- Remove the 4 screws and take off the head.
- Pull out the valve assembly. Inspect wear ring & lubricate. Do not attempt to disassemble the valve assembly.
- Pull out the piston assembly. Inspect wear ring and lubricate.

It is usually not necessary to pull-out the bumper for maintenance. To replace the bumper:

- Remove the 4 screws and take off the base/magazine assembly.
- Pull out and replace the bumper.

CLEANING THE VALVE

If the tool becomes sluggish or does not set the fastener correctly, it may indicate excessive dirt, dust, other particles, or even water, in the tool. The first step in troubleshooting is to clean up the head assembly.

- Disassemble the head assembly as described in previous section.
- Perform a visual inspection of the valve assembly. Ensure that the actuator is sliding easily. Clean and lubricate lightly. Do not attempt to take apart the actuator assembly.
- Clean the inside wall of the head and lubricate lightly with a non-detergent oil. Insert the valve assembly into the head and ensure that it is sliding easily.
- Ensure the piston assembly is sliding easily into the cylinder. It should offer some resistance, but if it moves too easily, it may be required to replace the piston wear-ring.

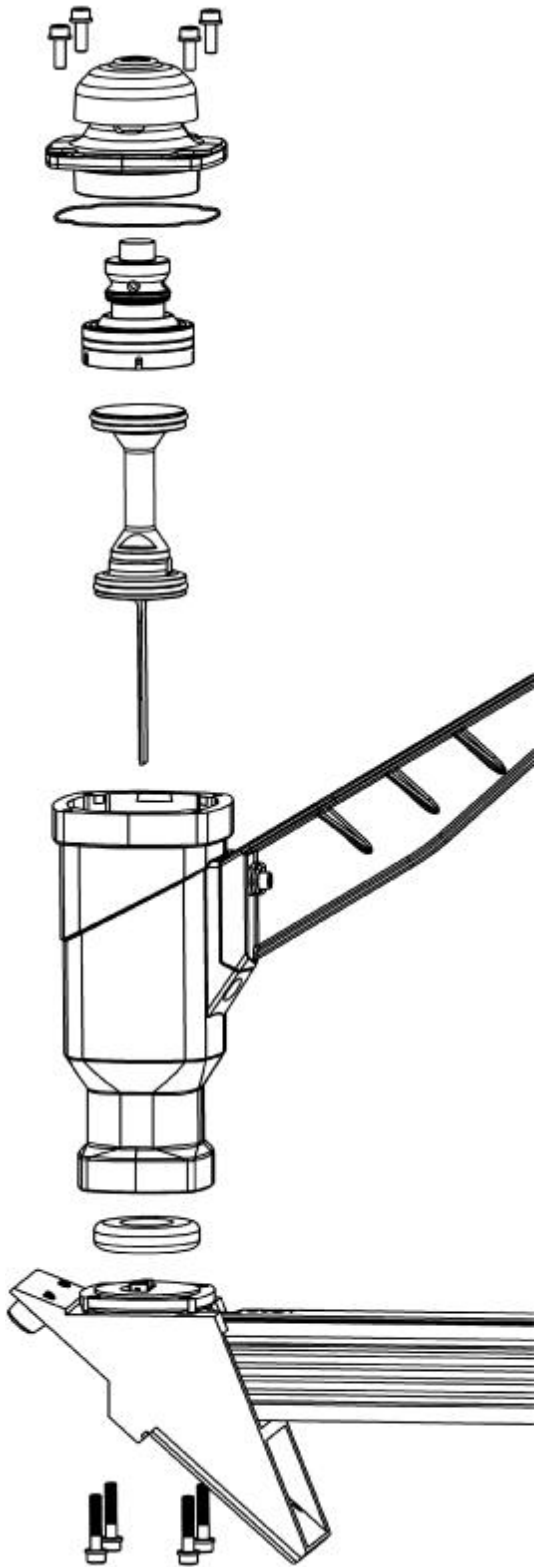

ASSEMBLING THE TOOL

This section describes how to re-assemble the tool after maintenance. The following procedure assumes that the base/magazine is already installed.

- Insert the piston assembly into the tool and engage the driving blade thru the opening of gate/foot assembly guiding channel.
- Insert the valve assembly into the head.
- Inspect the head gasket; replace if necessary. Place the gasket into the groove on the head flange. Some oil or grease will help to keep it in place during assembly.
- Insert the head assembly onto the body, making sure that the gasket stays in place. Screw in place.



After reassembly, always actuate the tool repeatedly **WITHOUT FASTENERS** against a piece of wood to insure proper operation.

TROUBLESHOOTING



TO PREVENT INJURY, ALWAYS DISCONNECT THE AIR SUPPLY HOSE WHEN ADJUSTING, SERVICING OR DISASSEMBLING THE TOOL.

FIRST: CHECK THE COMPRESSED AIR SUPPLY

Many of problems come from a faulty or inadequate compressed air supply system. Before attempting to repair the tool, the following points should be checked:

- Check the pressure at the output of the compressor; adjust to 80-100 psi (5.5-7.0 bar) as required.
- Check the tank pressure of the compressor & adjust the start/stop limits.
- Check the air delivery system; a 3/8" hose is recommended.
- Use fewer tools simultaneously; do not exceed the capacity of the compressor or of the delivery system.
- Drain water from the compressor.

SECOND: CHECK FOR AIR LEAKS

At rest, this tool should not have any air leaks. Before attempting to repair the tool and replace parts, check the following:

- Check all seals in head, valve and piston assemblies; replace if necessary.
- Check the top edge of main cylinder for burrs or dents.
- Clean & lubricate the head and valve assemblies; re-assemble the head assembly carefully.
- Check the interior of the head for scratches.

A more comprehensive list of tips and hints at

<http://ts.primatech.ca/tips>



SCHEMATICS

With your tool Serial Number at hand, go to our support web site to retrieve the schematic specific to your tool:

<http://ts.primatech.ca/145>



For more information, contact technical support:

by phone
by email

1 (800) 363-1962
support@primatech.ca



TOOL WARRANTY AND LIMITATIONS

Primatech warrants that newly purchased fastening tools, parts and accessories will be free from defects in material and workmanship (excluding wear parts) for the period shown below, after the date of purchase by the original user as evidenced by a valid purchase invoice.

ONE-YEAR LIMITED WARRANTY will apply to all parts, except those subjected to normal wear

WARRANTY STATEMENT

Primatech 's sole liability hereunder will be to replace any part or accessory which proves to be defective within the specific time period. Any replacement part or accessories provided in accordance with this warranty will carry a warranty for the remainder of the period of warranty applicable to the part it replaces. When repair or replacement of part or tool is required, the complete tool or part(s) must be returned to Primatech or at such authorized warranty service point of Primatech, transportation prepaid, with a copy of proof of purchase evidencing that the part or tool is within the warranty period. Serial # must be intact and legible for warranty to apply.

This warranty is void as to any tool which has been subjected to misuse, abuse, accidental or intentional damage, used with fasteners not meeting Primatech specifications, size or quality, improperly maintained, repaired with other than genuine Primatech replacement parts, damaged in transit or handling, or which, in Primatech 's sole opinion, has been altered, modified or repaired in a way that affects or detracts from the performance of the tool.

PRIMATECH MAKES NO WARRANTY, EXPRESSED OR IMPLIED, RELATING TO MERCHANTABILITY, FITNESS, OR OTHERWISE, EXCEPT AS STATED ABOVE, and Primatech's liability AS STATED ABOVE AND AS ASSUMED ABOVE is in lieu of all other warranties arising out of, or in connection with, the use and performance of the tool, except to the extent otherwise provided for by applicable law.

PRIMATECH SHALL IN NO EVENT BE LIABLE FOR ANY DIRECT, INDIRECT, OR CONSEQUENTIAL DAMAGES WHICH MAY ARISE FROM LOSS OF ANTICIPATED PROFITS OR PRODUCTION, SPOILAGE OF MATERIALS, INCREASED COST OF OPERATION, OR OTHERWISE. Any liability, if any, connected with the use of the tool shall terminate upon the expiration of the warranty period specified above.